

MODEL 253

Digital Impedance Meter

Instruction Manual

P/N 43761-CD
Rev F

This owner's manual was as current as possible when this product was manufactured. However, products are constantly being updated and improved. Because of this, some differences may occur between the description in this manual and the product you received.

TEGAM, INC.
TEN TEGAM WAY
GENEVA, OH 44041
TEL: (440) 466-6100
FAX: (440) 466-6110
www.tegam.com
Publication Date: June 2005

PROTECT AGAINST ELECTROSTATIC DISCHARGE

In this instrument there are MOSFET semiconductors, which can be damaged by electrostatic discharge during handling. The following precautionary procedures are recommended to minimize this possibility.



HANDLE STATIC SENSITIVE DEVICES ONLY AT A GROUNDING, STATIC-FREE WORK STATION

HANDLE DEVICES BY THE BODY. DO NOT TOUCH THE DEVICE LEADS.



BE SURE YOUR SOLDERING IRON TIP IS GROUNDING AND DO NOT USE SOLDER-SUCKERS THAT ARE NOT ANTI-STATIC PROTECTED



USE ANTI-STATIC PACKAGING FOR HANDLING AND TRANSPORT

KEEP PARTS IN MANUFACTURER'S PROTECTED CONTAINERS



DISCHARGE PERSONAL STATIC BEFORE HANDLING DEVICES



AVOID HANDLING WHENEVER POSSIBLE

DO NOT SLIDE STATIC SENSITIVE DEVICES OVER ANY SURFACE AND AVOID PLASTIC, VINYL AND STYROFOAM IN WORK AREAS



TABLE OF CONTENTS



DANGEROUS VOLTAGE POTENTIALS EXIST INSIDE THIS INSTRUMENT. MAINTENANCE INSTRUCTIONS WITHIN THIS MANUAL ARE FOR USE BY QUALIFIED SERVICE PERSONNEL ONLY. TO AVOID ELECTRICAL SHOCK, DO NOT ATTEMPT ANY SERVICING OTHER THAN THAT CONTAINED IN THE OPERATION INSTRUCTIONS UNLESS YOU ARE QUALIFIED TO DO SO.

1 DESCRIPTION

1.1 INTRODUCTION	1-1
1.2 SPECIFICATIONS	1-2

2 OPERATION

2.1 CONTROLS AND CONNECTORS	2-1
2.1.1 Front Panel	2-1
2.1.2 Rear Panel	2-3
2.2 OPERATING PROCEDURE	2-4
2.2.1 Power Requirements	2-4
2.2.2 Applying Power	2-5
2.2.3 Connection to Unknowns	2-6
2.2.3.1 Test Fixture Compensation	2-8
2.2.4 Function Selection	2-9
2.2.5 Range Selection	2-12
2.2.6 Summary of Operation	2-13
2.3 MEASUREMENT TECHNIQUES	2-14
2.3.1 Resistance Measurements at 120Hz (or 100Hz)	2-14
2.3.2 Capacitance Measurements	2-14
2.3.3 Inductance Measurements	2-17
2.3.4 Determining Quality Factor (Q) of Inductors	2-17
2.3.5 Determining Dissipation Factor (D) of Capacitors using Nomograph	2-18
2.3.6 Using the Bias Feature	2-20
2.3.7 Signal Output Terminals	2-21
2.3.8 Measuring Grounded Unknowns	2-21
2.3.9 Measuring Battery Impedance	2-24
2.3.10 Component Sorting	2-26

3 CIRCUIT DESCRIPTIONS

3.1 GENERAL DESCRIPTION	3-1
-------------------------	-----

TABLE OF CONTENTS (continued)

4 MAINTENANCE	
4.1 CALIBRATION PROCEDURE	4-1
4.1.1 Power Supply Check	4-2
4.1.2 Oscillator Adjust	4-2
4.1.3 L, C, R, G Alignment	4-2
4.1.4 Dissipation Factor (D) Alignment	4-3
4.2 MAINTENANCE	4-5
4.2.1 Preventive Maintenance	4-5
4.2.1.1 Cleaning	4-5
4.3 PREPARATION FOR CALIBRATION OR REPAIR SERVICE	4-6
4.4 WARRANTY	

SECTION 1

DESCRIPTION

1.1 INTRODUCTION

Model 253 Digital Impedance Meter is a semi-automatic instrument which permits rapid measurement of inductance (L), capacitance (C), resistance (R), conductance (G) and dissipation factor (D) at a test frequency of 1kHz. Measurement accuracy and versatility satisfies most demanding engineering or scientific applications.

This instrument has both an autoranging mode and a manual range selection mode. The autoranging feature eliminates the need for manual range selecting, thus saving time and avoiding operator errors. It is designed to measure an unknown and select the lowest corresponding range automatically, thereby providing the highest resolution display. When a series of measurements are to be made within a particular range, time can be saved by turning the range switch to the corresponding fixed range position. Front panel LED lamps indicate the unit of measurement being displayed by the 3-1/2 digit LED readout.

To operate, merely push the button for the desired function, manually turn the knob to the desired range, and connect the unknown. KELVIN KLIPS® test leads are included, thus ensuring true four-terminal connections.

Excellent reliability of the Model 253 is assured through use of solid-state devices and etched circuit board construction. Its small size is ideal for use on bench tops where work space may be at a premium. The carrying handle tilts the unit to a convenient viewing angle. Rear panel brackets provide line cord storage and enable it to be operated in a vertical position.

1.2 SPECIFICATIONS

		Ranges							
		0	1	2	3	4	5	6	7
Full Scale Values	L_s	200 μ H	2 mH	20 mH	200 mH	2 H	20 H	200 H	200 H
	C_p	200 pF	2 nF	20 nF	200 nF	2 μ F	20 μ F	200 μ F	2000 μ F
	R_s	2 Ω	20 Ω	200 Ω	2000 Ω	20 k Ω	200 k Ω	2000 k Ω	2000 k Ω
	G_p	2 μ S	20 μ S	200 μ S	2000 μ S	20 mS	200 mS	2000 mS	20 S
	D	1.999							
Accuracy (15°C to 35°C)	L_s	$\pm[0.25\% + (1 + 0.002R_s^*) \text{ digits}]^{**}$	$\pm[0.25\% + (1 + 0.001R_s^*) \text{ digits}]$					$\pm[0.25\% + (1 + 0.010R_s^*) \text{ digits}]$	$\pm[0.25\% + (1 + 0.010R_s^*) \text{ digits}]$
	C_p	$\pm[0.25\% + (1 + 0.002C_p^*) \text{ digits}]^{**}$	$\pm[0.25\% + (1 + 0.001C_p^*) \text{ digits}]$					$\pm[0.25\% + (1 + 0.010C_p^*) \text{ digits}]$	$\pm[0.25\% + (1 + 0.010C_p^*) \text{ digits}]$
	R_s	$\pm[0.25\% + (1 + 0.002L_s^*) \text{ digits}]$	$\pm[0.25\% + (1 + 0.001L_s^*) \text{ digits}]$					$\pm[0.25\% + (1 + 0.010L_s^*) \text{ digits}]$	$\pm[0.25\% + (1 + 0.010L_s^*) \text{ digits}]$
	G_p	$\pm[0.25\% + (1 + 0.002G_p^*) \text{ digits}]$	$\pm[0.25\% + (1 + 0.001G_p^*) \text{ digits}]$					$\pm[0.25\% + (1 + 0.010G_p^*) \text{ digits}]$	$\pm[0.25\% + (1 + 0.010G_p^*) \text{ digits}]$
	D	$\pm(1\% + 0.002)$ for L or C ≥ 200 counts $\pm(2\% + 0.010)$ for L or C 50 to 199 counts							$\pm(2\% + 0.010)$
Test Signal	Voltage C_p, G_p	1.0 VRMS			0.1 VRMS				0.01 VRMS
	Current L_s, R_s	100 mA	10 mA	1 mA	100 μ A	10 μ A		1 μ A	

* Digit count, same range.
 ** After correction for test lead zero reading.
 0°C to 15°C and 35°C to 50°C: add 0.1 (rated accuracy)/°C.

Table 1-1. Model 253 Specifications

Test Frequency: 1kHz \pm 1%

Unknown Excitation: The 1kHz voltage (V_x) and current (I_x) levels listed in Table 1-1 are held constant by an internal amplitude control circuit.

Measurement Rate: Four per second; one second is required for first reading after connecting unknown to terminals.

Measurement Display: 3-1/2 digit LED with decimal point. Blanked for overload conditions.

Unit Display: Unit of measurement being displayed by the LED readout is indicated by front panel LED lamps used in conjunction with the desired function button and the front panel range switch or autoranging mode.

External Bias: Rear panel terminals are provided for connection of external supply. 0V to 50VDC, 0.1A maximum. (Read Section 2.2.6 before using external bias.)

Static Charge Protection: Diode and resistor discharge network.

Connection to Unknown: Four-terminal, shielded, connections are provided by the KELVIN KLIPS® cable assembly (Tegam Part Number 43072) supplied with the Model 253.

Outputs: Analog signals of 1V per 1,000 counts, 1kΩ source resistance is available at rear panel. L, C, R, or G, with simultaneous output of D for L or C.

Power Consumption: 4 watts typical.

Power Requirements: 100 to 125V or 200 to 250V, 50/60Hz.

Fuse: 110V: 1/16A, 250VAC Slow-Blow

220V: 1/20A, 250VAC Slow-Blow

Size: Height (with feet) - 100mm (4 in.)

Width - 260mm (10 in.)

Depth (overall) - 370mm (14.6 in.)

Weight: 3.2kg (7 lb.)

Accessories supplied with Model 253:

KELVIN KLIPS® Four-Terminal Clips

Instruction Manual

Tegam Part No.

43072

43761

Options Available:

Tegam Part No.

Sorting Fixture Model 2001 (low frequency)

32001

Cable Assembly (for Model 2001 connection)

43586

Front Panel Dust Cover

43374

SECTION 2

OPERATION

2.1 CONTROLS AND CONNECTORS

2.1.1 Front Panel

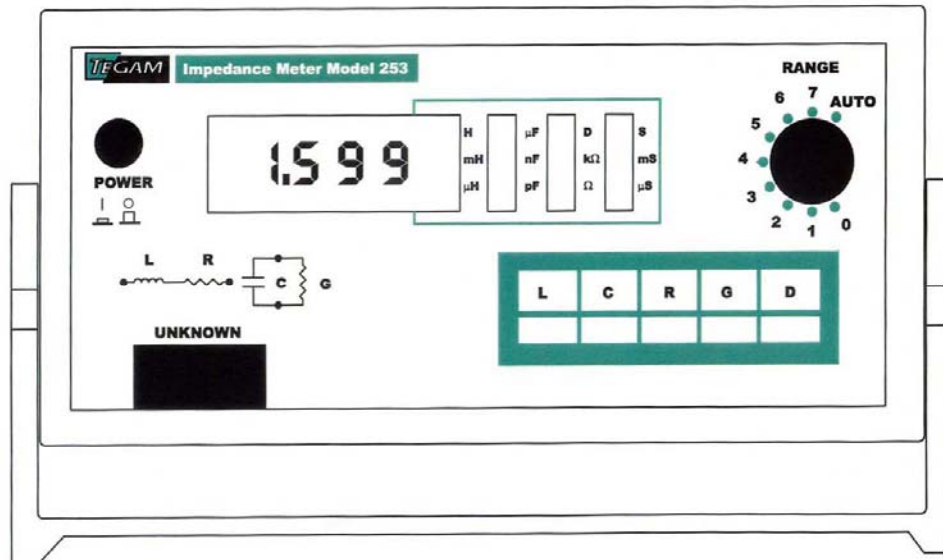

Figure 2-1. Model 253 Front Panel

1. ON/OFF Switch – A push-on, push-off switch for applying and removing power from the instrument.
2. UNKNOWN Connector – Terminals designed to be used with KELVIN KLIPS® test leads (Tegam Part No. 43072), provided with Model 253, to provide a true four-terminal connection to the unknown or test fixture.
3. L, R, C, and G Pushbuttons – Function pushbuttons select the type of meter circuit that will measure series inductance (L) and resistance (R) or parallel capacitance (C) and conductance (G).

4. D Pushbutton -- The push-to-read D (dissipation factor) pushbutton displays the D of a capacitor or inductor when the C or L function is selected.
5. Range Switch -- Selects the decimal multiplier and units of measurement for the meter circuit being used. Each range, 0 – 7, can be individually selected or the AUTO position puts the instrument in auto ranging mode..
6. Display — A 3-1/2-digit readout for all functions.
7. Units Indicators – Front panel LED lamps indicate the units of measurement. The basic multipliers and units are H (henrys), mH (millihenrys), μ F (microfarad), nF (nanofarad), $k\Omega$ (kilohms), Ω (ohms), S (siemens), mS (millisiemens), μ S (microsiemens), and D (dissipation factor).
8. Tiltstand Handle – Aids portability; tilts instrument for easier viewing of the LED display.

2.1.2 Rear Panel

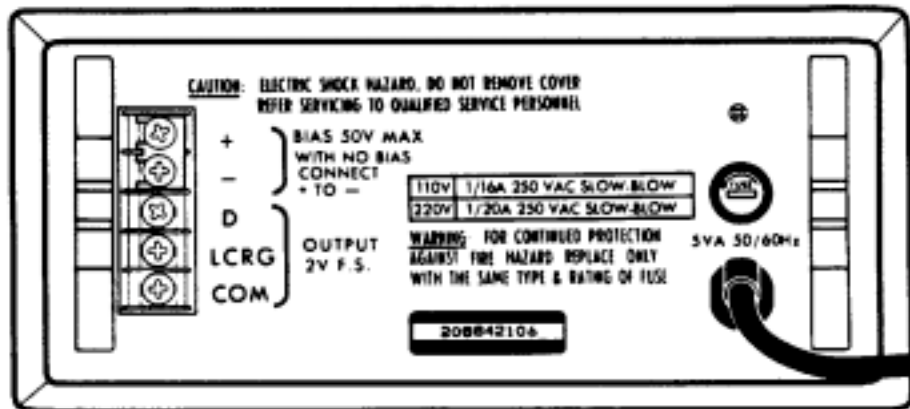

Figure 2-2. Model 253 Rear Panel

1. Bias Terminals – Allows application of a 0V to 50VDC, 0.1A maximum bias to the capacitor being measured. (The shorting bar must be in place when not using bias feature.) See Section 2.3.6 before using external bias.
2. Output Terminals – Provides two analog signals proportional to the function selected (L, R, C, or G) and D (for L and C). These terminals can be used with external DVM's (for increased full scale readings or resolution capability), with chart recorders, or with limits comparators, such as the Tegram Model 1412B.
3. Fuse – A 1/16A, 250V, type MDL Slow Blow for 110V line voltage, or a 1/20A, 250V type MDL Slow Blow for 220V line voltage.

2.2 OPERATING PROCEDURE

2.2.1 Power Requirements

Before turning the power ON, make sure the instrument is set to the proper line voltage. The Model 253 contains an internal slide switch to select the nominal line voltage (see Figure 2-3). In its up position, the switch selects 100 to 125VAC, 50/60Hz operation. In the down position it selects 200 to 250VAC, 50/60Hz operation.



WHEN CHANGING FROM 110VAC OPERATION TO 220VAC OPERATION (OR IN OPPOSITE ORDER), BE SURE TO REPLACE THE REAR PANEL AC FUSE WITH THE PROPER VALUE FOR THE LINE VOLTAGE SELECTED.

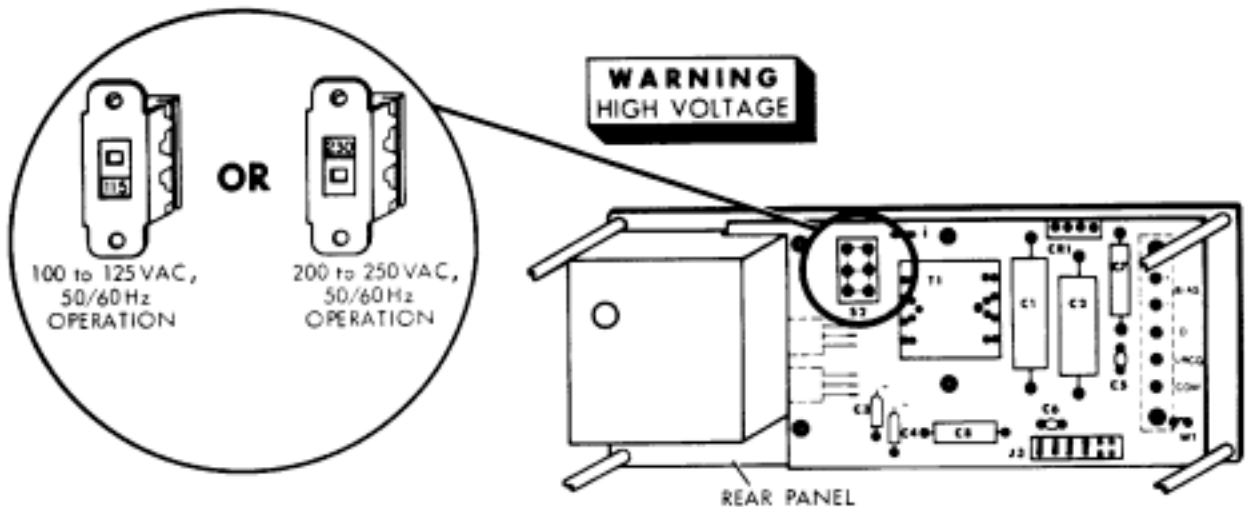

Figure 2-3. Line Voltage Switch

Because of differing power requirements, all instruments shipped outside the United States are without a power cord connector. When placing a connector on the power cord, care must be taken to assure the wires are connected properly. The green or green with yellow stripe wire is always connected to earth ground. The white or light blue wire is connected to the neutral side of the power line. And, the black or brown wire is connected to the high side of the power line.

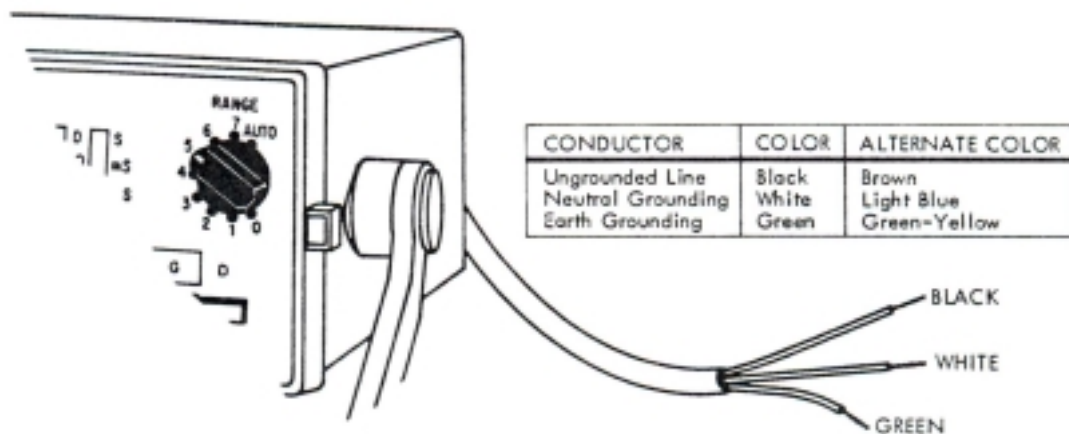

Figure 2-4. Power Cord

2.2.2 Applying Power

The push-on, push-off, ON/OFF button in its depressed position applies power to the measurement circuitry. When power is applied, the LED display lights and reads zero when in C and G modes or the display is blank with the decimal point lit in the L and R modes.

2.2.3 Connection to Unknowns

The KELVIN KLIP® test lead set (Tegam Part No. 43072) is plugged into the 253's front panel UNKNOWN connector. The test leads connector cover is spring-locking and should be squeezed together before inserting or removing.

The test leads provide a shielded, four-terminal connection to the unknown (see Figure 2-5a). The clip with the red hinge-spool provides the HI DRIVE and HI SENSE connections to the unknown and the clip with the black hinge-spool make the LO DRIVE and LO SENSE connections.

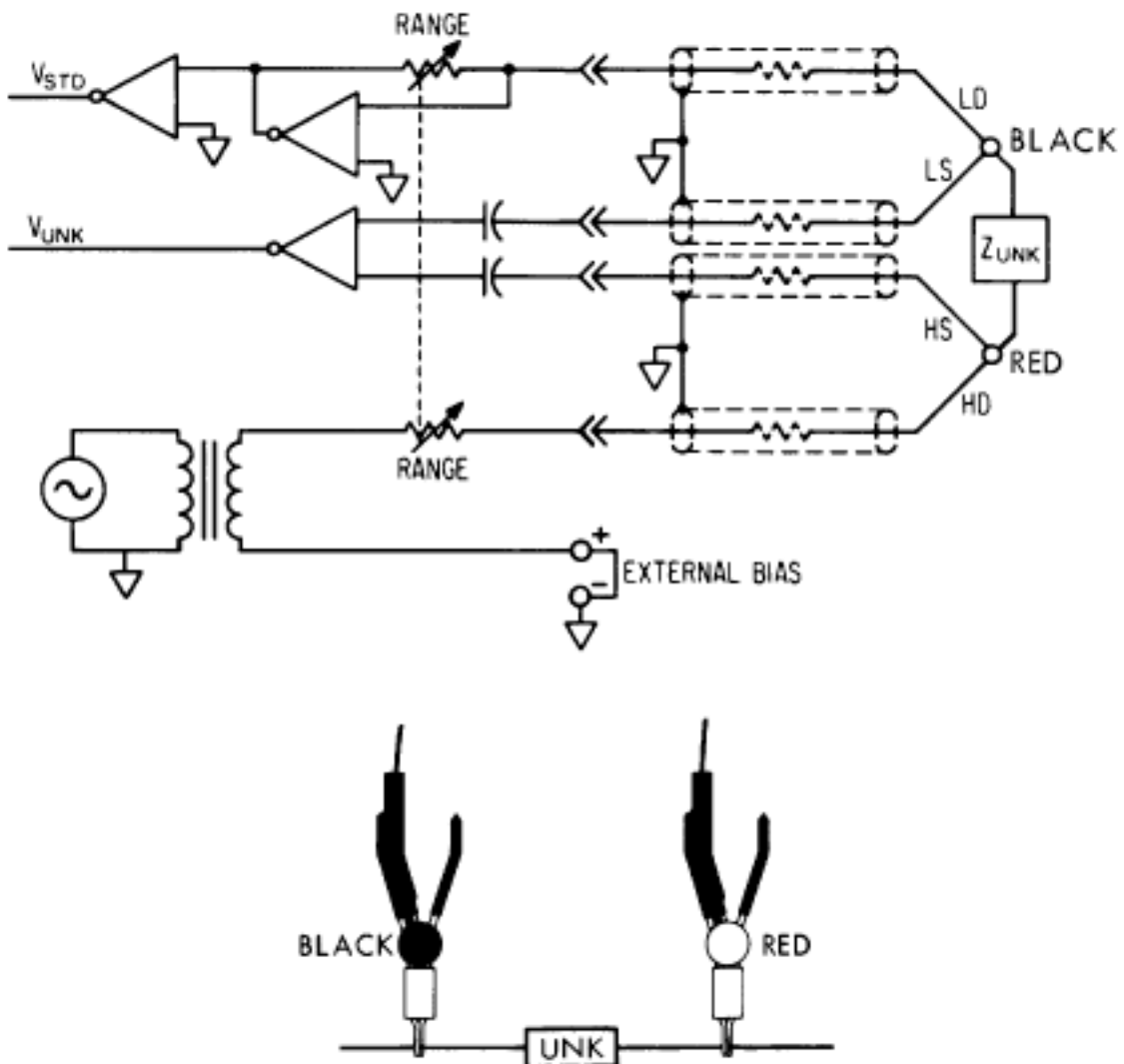

Figure 2-5a.

For connection to three terminal unknowns (the third connection is to ground), a ground wire must be added to the test lead set. This wire is connected as in Figure 2-5b.

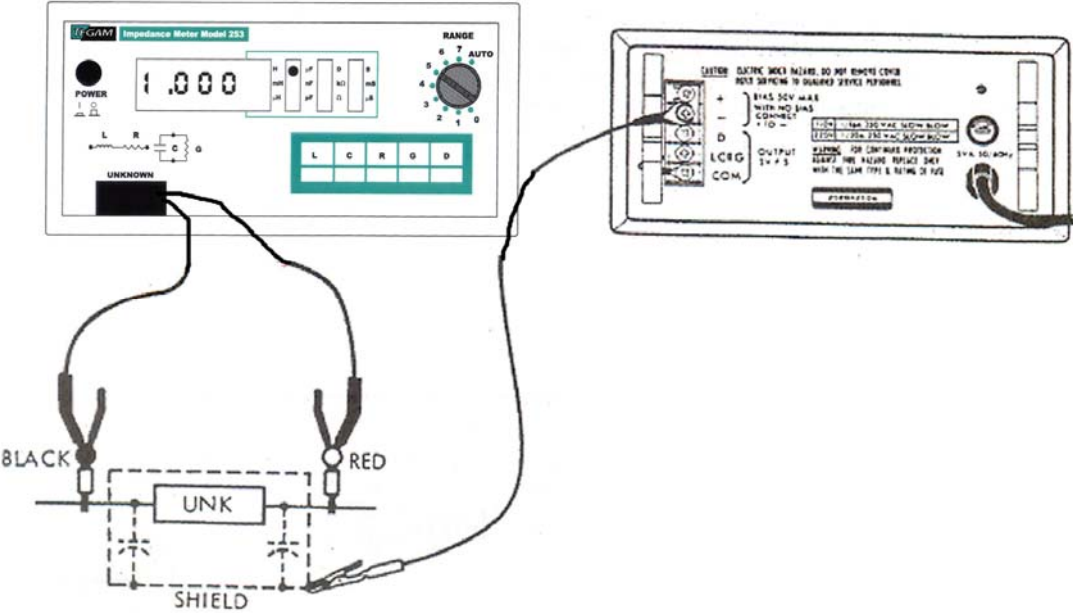

Figure 2-5b

2.2.3.1 Test Fixture Compensation

The Model 253 uses a 3.3pF capacitor (C6 in Figure 2-6) to compensate for the capacitance of the test leads. If the 253 is used with a test fixture, the larger capacitance of the fixture must also be compensated for. There are two methods for compensating this larger capacitance. The first method is to make a zero capacitance measurement with the test fixture connected. This reading is mentally subtracted from all other measurements.

The second method for compensating the larger capacitance is to change the value of C6 from 3.3 pF to 10 pF and to add an external trim capacitor. The external trim capacitor is connected in parallel with the unknown and should be of such a value that the test fixture capacitance can be trimmed to zero. Typically, the maximum value of this trim capacitor is 15pF. The trim capacitor can either be added to the test cable, between Terminals 1 and 3 of the connector as shown in Figure 2-6, or it can be added to the test fixture.

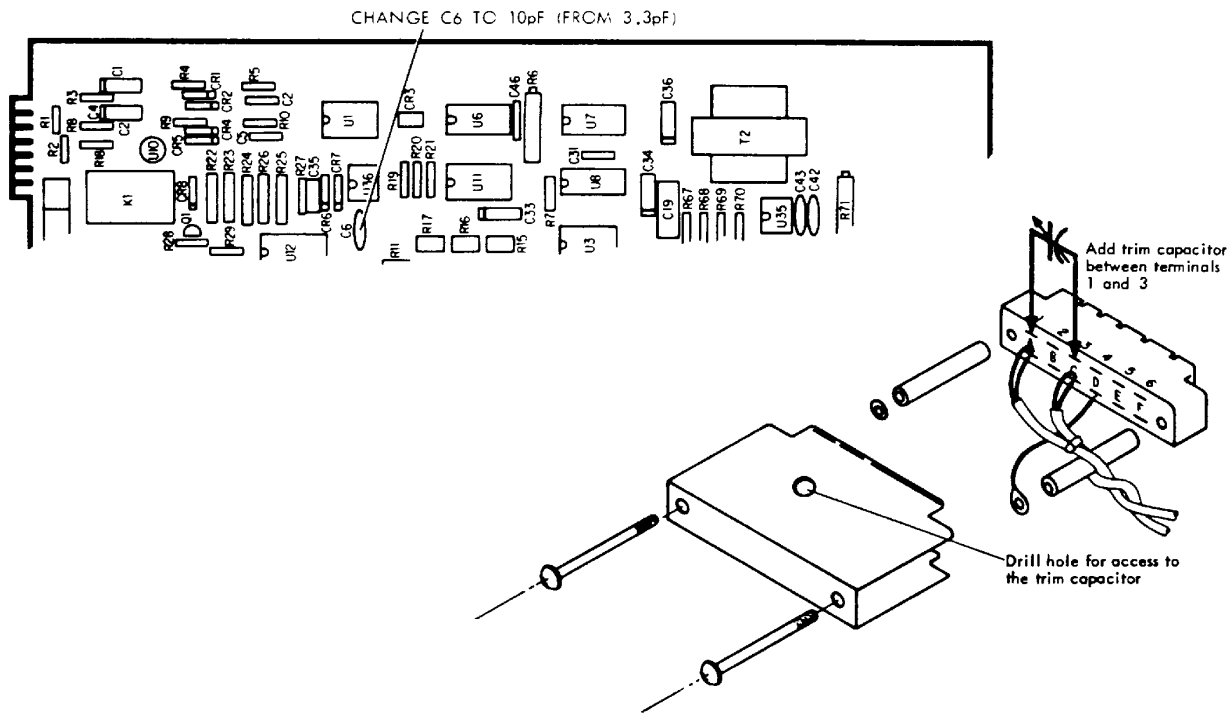
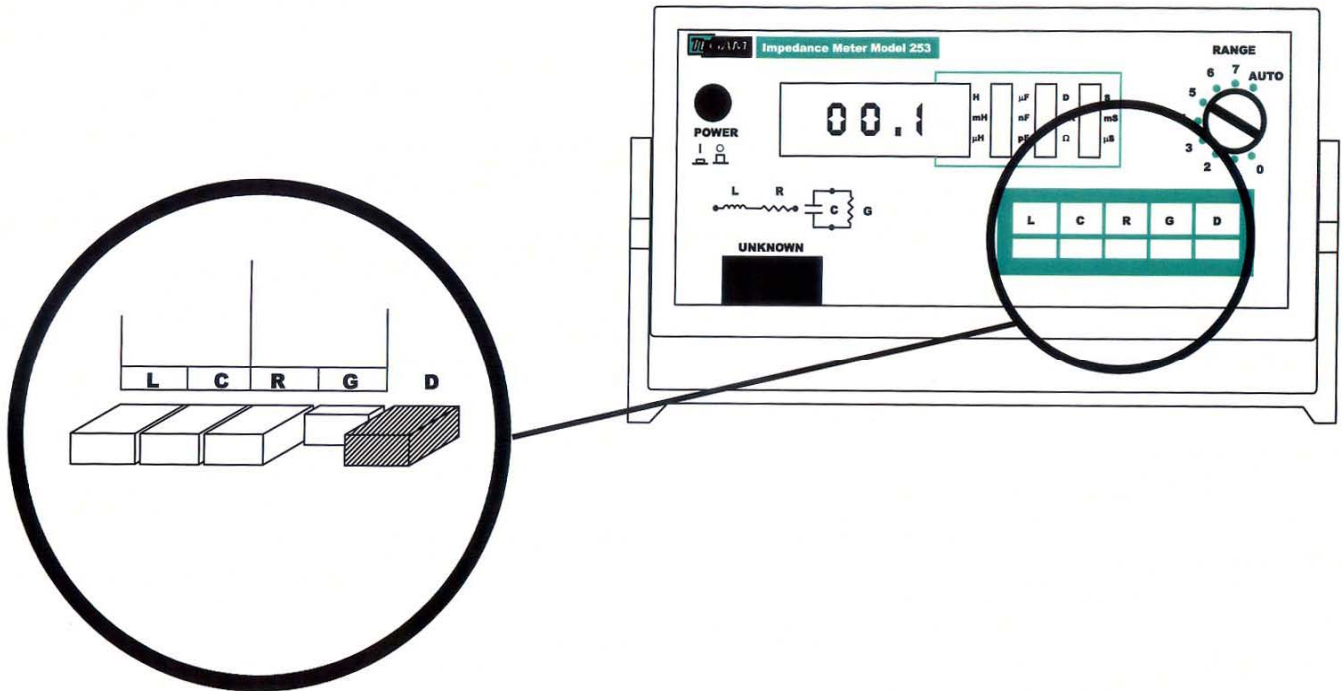

Figure 2-6. Test Fixture Compensation

Example: Select the conductance measurement function. (Depress the G Pushbutton.)



If a negative sign appears on the display when measuring an unknown, possible causes are:

- “C” button has been pushed when measuring an inductor.
- “L” button has been pushed when measuring a capacitor.
- The unknown is more capacitive (or inductive) than suspected. For example, an Inductor that resonates below 1 kHz will measure as though it were a capacitor.
- A diode requires bias voltage (a negative reading may appear if bias voltage is not applied).

To measure the dissipation factor (D) of a capacitor or inductor, push and hold the D button while the C or L function is selected. (The display will blank if D is pushed, while the unit is in R or G mode and the unknown is resistive).

When measuring the conductance (G) of a capacitor or the resistance (R) of an inductor, the R or G reading may be quite small. In trying to acquire more resolution by moving the range switch to the next lower range, the display will usually blank, indicating overload. Blanking occurs because the instrument is still monitoring the reactive component (L or C) in addition to measuring and displaying the loss component (R or G). In moving to the next lower range, the reactive component becomes too large for the lower range causing overload and a blanked display.

Example: while measuring a $0.82\mu\text{F}$ capacitor using the $2\mu\text{F}$ range, the 253 display reads:

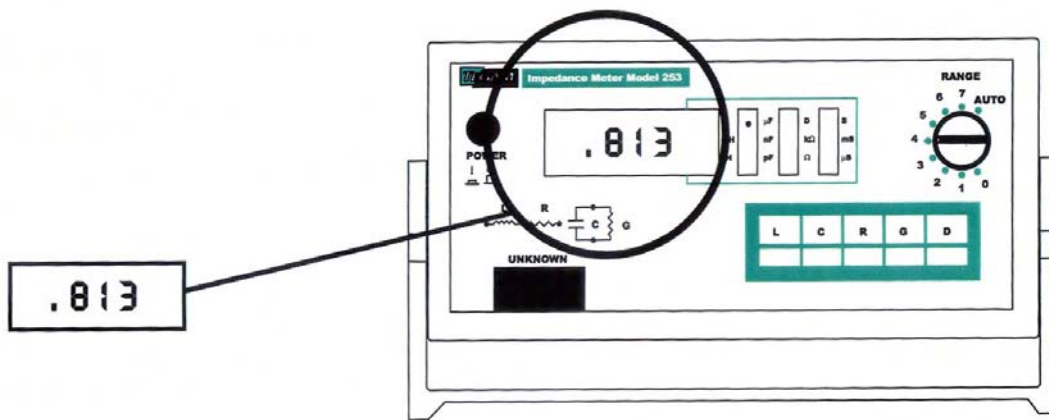

Switching to the conductance (G) mode, the display may read:

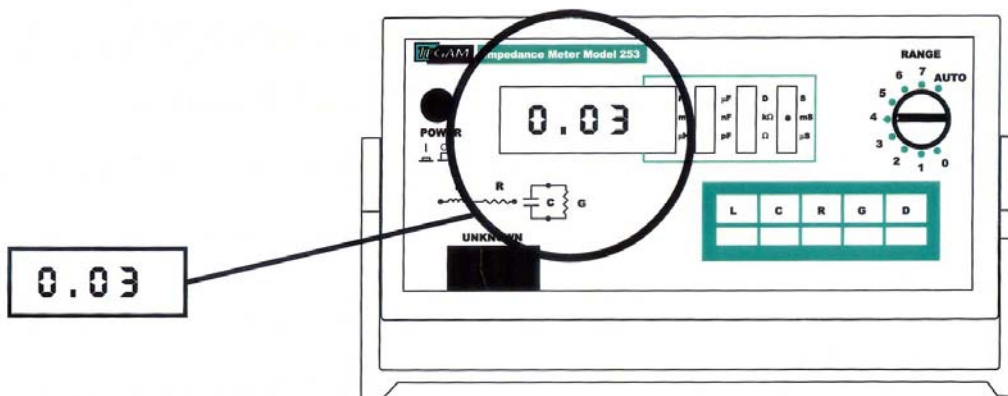

Trying to investigate this reading, you down range from the 20mS range to the 2000 μ S range. The display blanks:

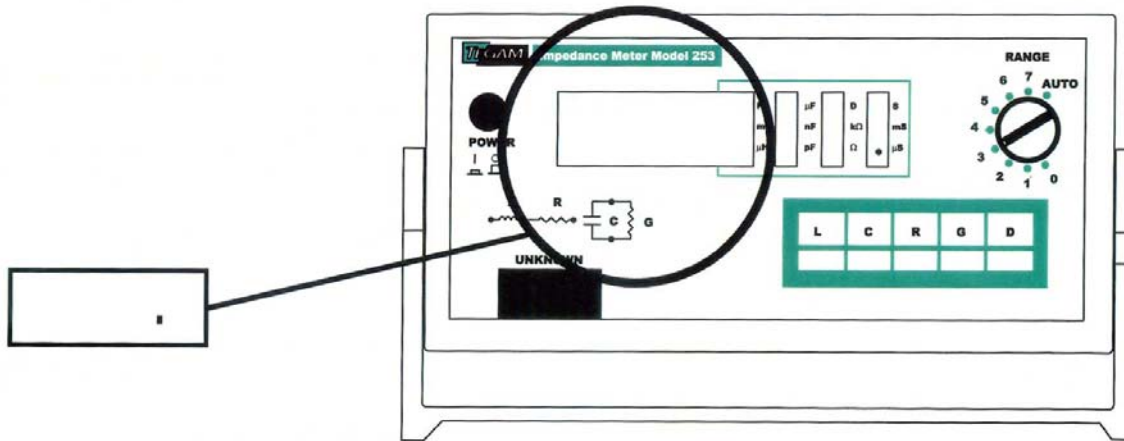

The display blanks because while ranging from 20mS to 2000 μ S, the capacitance range changed from 2 μ F, to 200nF. Since 0.82 μ F is too large to measure on the 200nF range, an overload occurs and the display blanks.

2.2.5 Range Selection

Measurement ranges are selected either manually or automatically via a nine position rotary switch. Switch positions 0 – 7 manually select the corresponding range (See Figure 2 – 7). For maximum accuracy, select the range that gives the largest on-scale reading. The AUTO position automatically selects the lowest corresponding range to give the highest resolution display.

		Ranges							
		0	1	2	3	4	5	6	7
Full Scale Values	L _s	200 μ H	2 mH	20 mH	200 mH	2 H	20 H	200 H	200 H
	C _p	200 pF	2 nF	20 nF	200 nF	2 μ F	20 μ F	200 μ F	2000 μ F
	R _s	2 Ω	20 Ω	200 Ω	2000 Ω	20 k Ω	200 k Ω	2000 k Ω	2000 k Ω
	G _p	2 μ S	20 μ S	200 μ S	2000 μ S	20 mS	200 mS	2000 mS	20S
	D	1.999							

Figure 2 – 7 Range Chart

Autoranging operates for the major component of the unknown i.e., C for capacitors, L for inductors, R for resistors. When measuring the minor component of the unknown, i.e. R of inductors, G of capacitors, use manual ranging.

The units of the displayed reading, i.e. μH , mH , etc., are indicated by front panel LED lamps. If either the reactive or resistive value of the unknown exceeds the range selected, the display will blank.

Example: Set the instrument to measure 100pF capacitors.

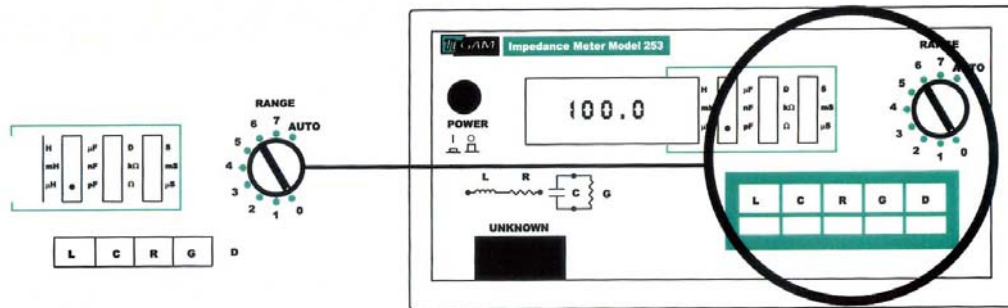

Example: Set the instrument to measure 100k Ω resistors.

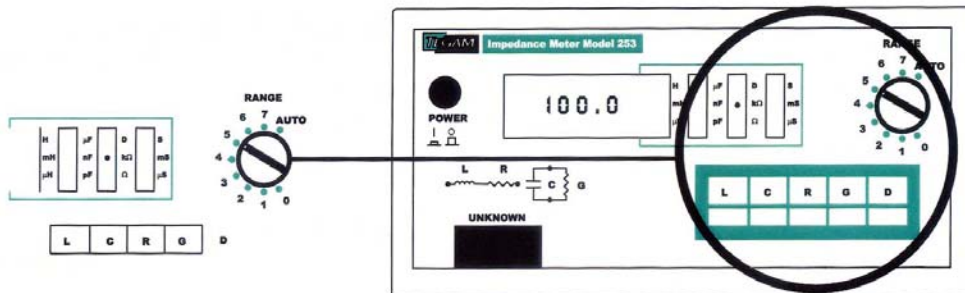

If the value of a component is not known, set the instrument to its highest range before connecting the test leads. Step the instrument down one range at a time until the range with the highest resolution is reached. If the display is blank after the component is connected, the value of the component is too large to measure directly, see Section 2.3 for alternate measurement techniques.

2.2.6 Summary of Operation

Press the appropriate function button (L, C, or G) and connect the KELVIN KLIPS® to the unknown. For maximum accuracy, select the range that gives the largest on-scale reading. When the RANGE switch is in AUTO position, the instrument automatically selects the lowest corresponding range to give the highest resolution display. The measurement is displayed after one second or less. Repetitive measurements are made at the rate of four per second. The range LED lamps indicate the readout units (i.e. μH , mH , H, etc.). If the value of the unknown exceeds the range selected, the display will remain

blanked. To measure the dissipation factor of a capacitor or inductor, push and hold the D button while the C or L function is selected.

2.3 MEASUREMENT TECHNIQUES

2.3.1 Resistance Measurements at 1kHz

When using the resistance function, the maximum measurement is 1999k Ω . For measurements from 1999k Ω to 1000M Ω , use the G (conductance) function where $G = 1/R$ or $R = 1/G$. Measurement accuracy is determined by $\pm (0.25\% + 1 \text{ digit})$ where 1 digit will be $\pm 100\%$ at 1000M Ω , $\pm 10\%$ at 100M Ω , and $\pm 1\%$ at 10M Ω .

High-value, bobbin-type, wire-wound resistors have shunt capacitance which may affect measurements by appearing as “-Ls”. This causes some difference between AC and DC resistance measurement values.

The resistive component (R_s) of inductors and transformers, when measured at 1kHz, will differ from the DC winding resistance. If the core material is air or low loss (e.g. powdered permalloy), the AC and DC values will be nearly equal. For laminated magnetic cores, the AC resistance will be greater than the winding resistance (sometimes much greater). This is caused by the core losses which change both with frequency and test current level.

2.3.2 Capacitance Measurements

Shielded devices. For shielded devices, the shield should be connected to the rear panel –Bias terminal to provide proper guarding.

Most two- and four-terminal cables or sorting fixtures are not guarded immediately adjacent to where the unknown capacitor is connected, and a zero capacitance reading can change by a few picofarads whenever the ends of the cable or fixture terminals are physically moved. Always maintain the physical orientation of the leads or terminals after checking for zero capacitance. Subtract zero-capacitance reading from the capacitance reading for the unknown.

Equivalent Series Resistance (ESR). To measure series resistance of capacitors, use the Rs function. Series resistance will be displayed on the front panel.

Series Capacitance. The Ls function can be used to measure series capacitance. (The capacitor is measured with a constant current rather than a constant voltage.) A negative reading will be shown, and the following equation must be used to convert the “-Ls” readings to the “Cs” values:

$$C_s = \frac{1}{(2\pi f)^2 (L_s)}$$

Where: f = frequency in hertz

Cs = series capacitance in farads

Ls = series inductance in henrys (ignore sign)

Dissipation factor (D). The D of large value electrolytic capacitors can be determined using the Ls and Rs functions using the same range. The following equation converts the Rs and Ls, in counts (ignore the Sign and decimal point), to D values:

$$D = 1.59 \times \left(\frac{R_s}{L_s} \right) \text{ for } 100\text{Hz and } 1\text{kHz operation}$$

$$D = 1.33 \times \left(\frac{R_s}{L_s} \right) \text{ for } 120\text{Hz operation}$$

Where: D = dissipation factor
Rs = equivalent series resistance reading in counts
Ls = series inductance in counts

Parallel Capacitance Measurements. The relation between parallel and series capacitance measurements is:

$$C_s = (1 + D^2) C_p \quad \text{where } D = G_p / 2\pi f C_p$$

The following graph illustrates the relation between C_s and C_p . The graph is used to obtain a C_s value for a capacitor by measuring the C_p and D values of the capacitor. To locate the C_s value, find the measured D value along the horizontal axis of the graph. (The D reading from the Model 252 will be a Dissipation Factor value not a Percent Dissipation value.) Move up the graph to the B curve and read the corresponding value on the right hand vertical axis. Multiply the measured C_p value by this reading to obtain the desired C_s value.

The A curve on the graph is used with the vertical axis in the same manner as described above. The A curve and left hand scale provide the Percent Difference between C_s and C_p .

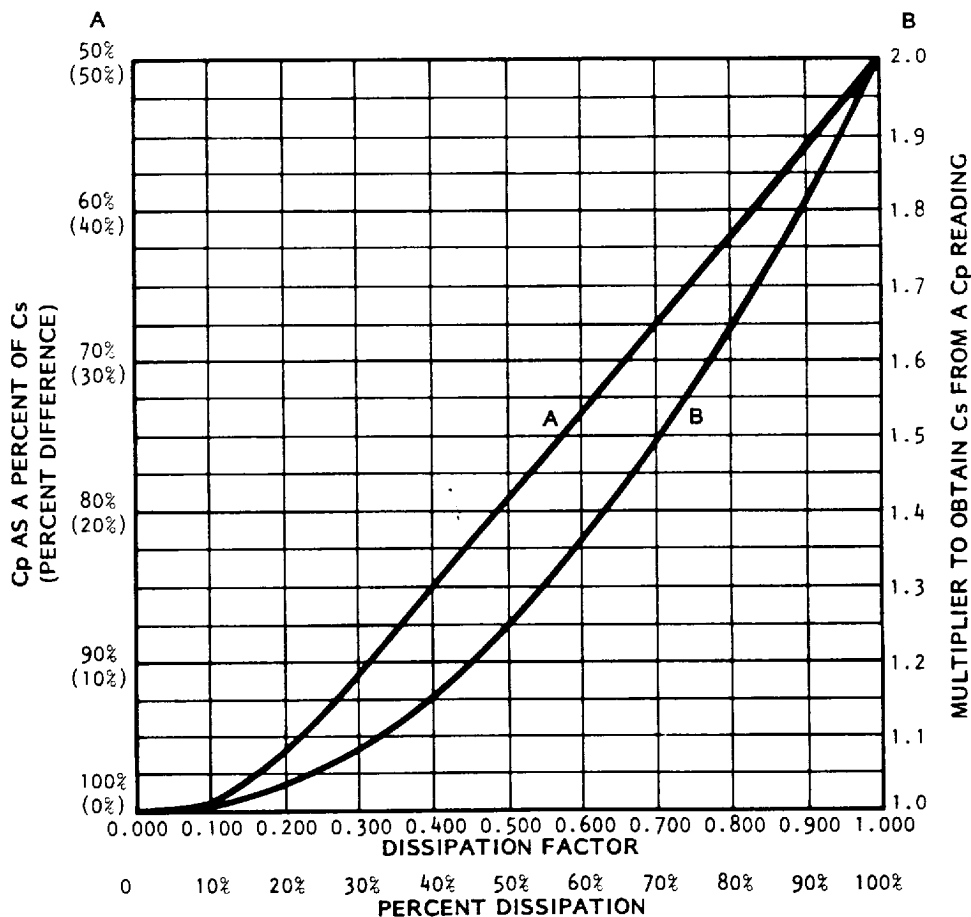

2.3.3 Inductance Measurements

The Model 253 measures the total impedance connected to its terminals. Both the unknown inductor and its leads contribute to this impedance. The leads have some resistance and inductance which affect the value read from the meter.

In making high inductance measurements, avoid AC pickup and keep the stray capacitance to a minimum. To minimize both effects, keep hands as far as possible from the inductor being measured. Keep the leads as short and direct as possible. Take care to avoid coupling stray magnetic fields into the inductor.

For greatest accuracy on low inductance measurements, minimize the lead impedance. Closely spaced, twisted leads will reduce the inductance and pickup of stray fields. The KELVIN KLIPS® Cable Assembly will add about 0.5µH to Ls and 0 mΩ to Rs. Short the test leads together and subtract the reading from the unknown inductance measured.

Measuring leakage inductance of transformer windings is an easy task for the Model 253 since there are no "false nulls" as found in manually-balanced bridges.

2.3.4 Determining Quality Factor (Q) of Inductors

To determine the Q of inductors, push the D button, record the D reading and calculate Q from the equation $Q = 1/D$. This procedure works well for $Q \geq 0.5$ (or $D \leq 2$). For $Q \leq 0.5$, measure the inductance of the unknown and record the readout display in digits only. With the RANGE switch in the same position, press the R button and note the readout display in digits, only. Do not record the decimal point or range multiplier for Ls or Rs; they are not required. Turn to Figure 2-8 for the D-Q nomograph. Use a straightedge to line up the Ls digits recorded (left-hand scale) with the Rs digits recorded (right-hand scale). Q is taken from the left-hand side of the center scale where the straightedge crosses. For example, with an Ls digital display of "300" and an Rs digital display of "600", Q is 0.3. Accuracy of Q is primarily limited by interpolation of the nomograph.

Although the nomograph provides a convenient way to approximate Q, it may be determined more accurately by the formula:

$$Q = 0.628 \times \left(\frac{Ls}{Rs} \right) \text{ for } 100\text{Hz and } 1\text{kHz operation}$$

$$Q = 0.754 \times \left(\frac{Ls}{Rs} \right) \text{ for } 120\text{Hz operation}$$

Where: Q = Quality factor

Rs = equivalent series resistance reading in counts

Ls = series inductance in counts

See Table 1-1 for accuracy of Ls and Rs measurements.

2.3.5 Determining Dissipation Factor (D) of Capacitors Using Nomograph

Model 253 will measure dissipation factor up to 1.999. For D values greater than 2 the nomograph should be used. Measure the capacitance of the unknown and record the readout display in digits only; do not record the decimal point. With the RANGE switch left in the same position, push the G button and note the readout display in digits only; do not record the decimal point. Turn to Figure 2-8 for the D-Q nomograph. Use a straightedge to line up the Cp digits recorded (left-hand scale) with the Gp digits recorded (right-hand scale). D is taken from the right-hand side of the center scale where the straightedge crosses. For example, with a Cp digital display of "200" and a Gp digital display of "300", D is 2.3. Accuracy of D is primarily limited by interpolation of the nomograph.

Dissipation factor may be determined more accurately by the formula:

$$D = 1.59 \times \left(\frac{G_p}{C_p} \right) \text{ for } 100\text{Hz and } 1\text{kHz operation}$$

$$D = 1.33 \times \left(\frac{G_p}{C_p} \right) \text{ for } 120\text{Hz operation}$$

Where: D = dissipation factor
Gp = parallel conductance reading in counts
Cp = parallel capacitance in counts

See Table 1-1 for accuracy of Cp and Gp measurements.

Electrolytic capacitors with high dissipation are usually unstable and the measured values may drift.

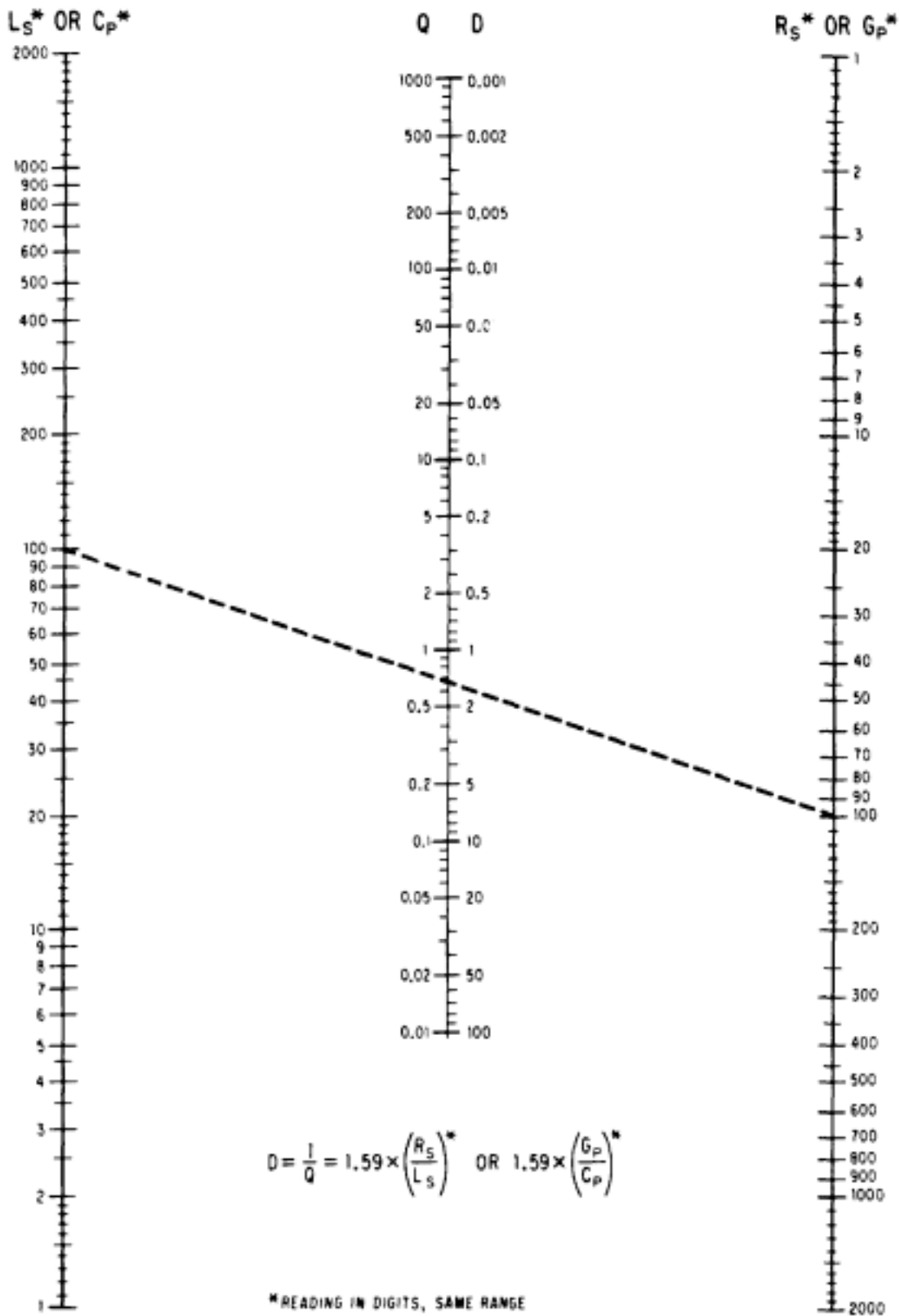

Figure 2-8. Model 253 D-Q Nomograph

2.3.6 Using the Bias Feature

WARNING

TO AVOID PERSONAL INJURY FROM ELECTRICAL SHOCK OBSERVE SAFETY PROCEDURES AS NEEDED FOR THE BIAS VOLTAGE APPLIED.

Bias voltage is necessary or desirable when measuring the capacitance of diodes or of some electrolytic or tantalum capacitors.

There is a provision on the rear panel for connecting an external bias source of zero to 50VDC. Remove the shorting link between BIAS terminals when using this feature.

If the external bias supply is not a low AC impedance type, it should have a capacitor bypass of five times the range full-scale value connected across the bias terminals. The bias supply should be current limited to 0.1A maximum.

With no bias supply connected, the rear-panel + and – terminals must be strapped together.

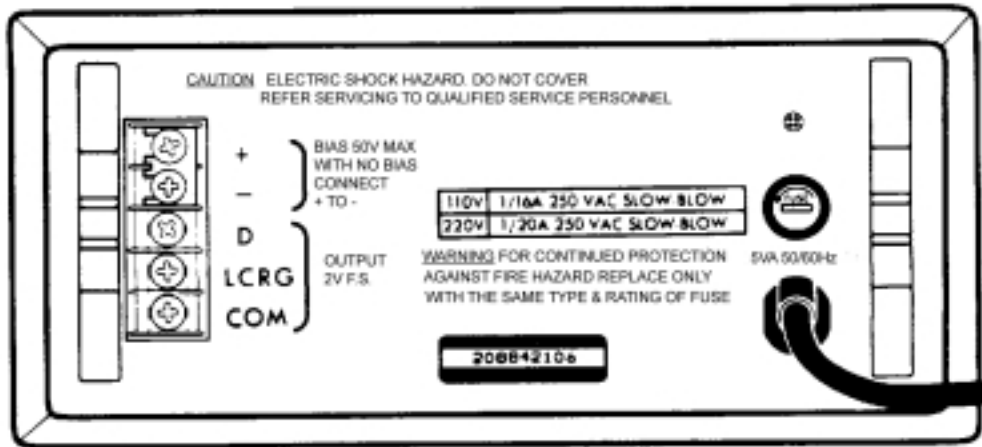

Figure 2-9. Rear Panel

2.3.7 Signal Output Terminals

Terminals are provided on the Model 253's rear panel for connecting external devices: digital voltmeters to increase full-scale resolution or simultaneous D reading; chart recorders to evaluate unknowns with changing impedances; limits comparators (Tegam Model 1412B) for HI, LO, GO, and HI D component sorting.

The analog output signals are proportional to the function selected (L, C, R, or G) and D (for L and C only). Specifications for these signals are:

Scale Factor	1V per 1000 counts
Source Resistance	1000 Ω
Accuracy	$\pm(0.25\%$ of reading + 1mV)

2.3.8 Measuring Grounded Unknowns

The model 253 is designed to measure ungrounded components. However, with a minor modification, it can be used to measure impedances that are connected directly or tightly coupled to earth ground.

This first procedure outlines the modification of all instruments with serial numbers 928999 and smaller.

1. Remove all instrument power.
2. Remove instrument cover by unscrewing the two cover screws and sliding the cover off.



TO AVOID PERSONAL INJURY FROM ELECTRIC SHOCK DO NOT REMOVE INSTRUMENT COVERS OR PERFORM ANY MAINTENANCE OTHER THAN DESCRIBED IN THIS MANUAL. INSTALLATION AND MAINTENANCE PROCEDURES DESCRIBED IN THIS MANUAL ARE TO BE PERFORMED BY QUALIFIED SERVICE PERSONNEL ONLY.

2.3.7 Using the Bias Feature

WARNING

TO AVOID PERSONAL INJURY FROM ELECTRICAL SHOCK OBSERVE SAFETY PROCEDURES AS NEEDED FOR THE BIAS VOLTAGE APPLIED.

Bias voltage is necessary or desirable when measuring the capacitance of diodes or of some electrolytic or tantalum capacitors.

There is a provision on the rear panel for connecting an external bias source of zero to 50VDC. Remove the shorting link between BIAS terminals when using this feature.

If the external bias supply is not a low AC impedance type, it should have a capacitor bypass of five times the range full-scale value connected across the bias terminals. The bias supply should be current limited to 0.1A maximum.

With no bias supply connected, the rear-panel + and – terminals must be strapped together.

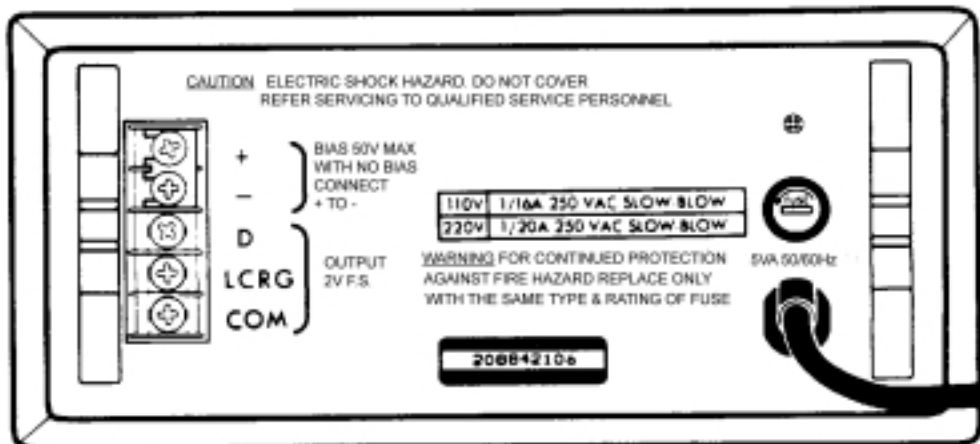

Figure 2-9. Rear Panel

2.3.9 Signal Output Terminals

Terminals are provided on the Model 253's rear panel for connecting external devices: digital voltmeters to increase full-scale resolution or simultaneous D reading; chart recorders to evaluate unknowns with changing impedances; limits comparators (Tegam Model 1412B) for HI, LO, GO, and HI D component sorting.

The analog output signals are proportional to the function selected (L, C, R, or G) and D (for L and C only). Specifications for these signals are:

Scale Factor	1V per 1000 counts
Source Resistance	1000 Ω
Accuracy	\pm (0.25% of reading + 1mV)

2.3.10 Measuring Grounded Unknowns

The model 253 is designed to measure ungrounded components. However, with a minor modification, it can be used to measure impedances that are connected directly or tightly coupled to earth ground.

This first procedure outlines the modification of all instruments with serial numbers 928999 and smaller.

3. Remove all instrument power.
4. Remove instrument cover by unscrewing the two cover screws and sliding the cover off.



TO AVOID PERSONAL INJURY FROM ELECTRIC SHOCK DO NOT REMOVE INSTRUMENT COVERS OR PERFORM ANY MAINTENANCE OTHER THAN DESCRIBED IN THIS MANUAL. INSTALLATION AND MAINTENANCE PROCEDURES DESCRIBED IN THIS MANUAL ARE TO BE PERFORMED BY QUALIFIED SERVICE PERSONNEL ONLY.

3. Locate the Power Supply Circuit Assembly, Part No. 53157. (Attached to the rear panel.)
4. Remove jumper wire W1 from this assembly (see Figure 2-10).

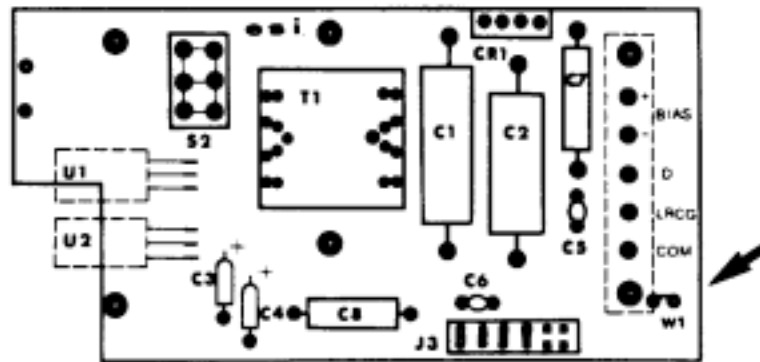

Figure 2-10. Power Supply Circuit Assembly

5. Locate the Range Switch on the front panel.
6. Unsolder and isolate the ground solder lug from the Range Switch terminal and black wire, making sure that the black wire remains attached to the Range Switch terminal (see Figure 2-11).

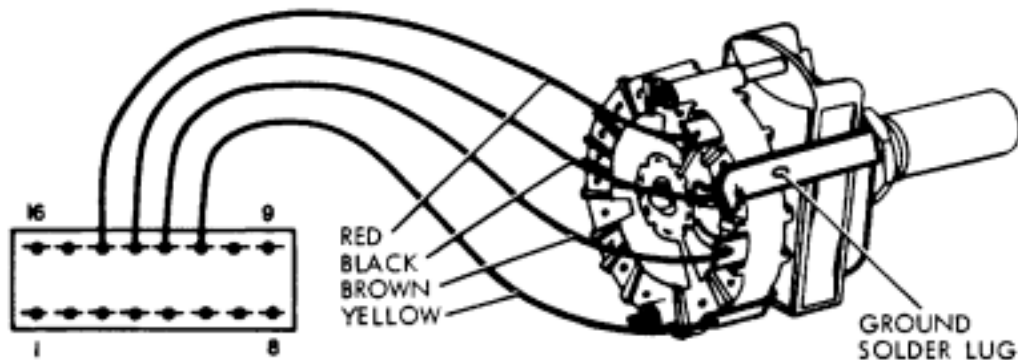

Figure 2-11

7. Replace instrument cover.

The modification of instruments with Serial Numbers 929000 and greater is as follows:

1. Locate the connector strip on the rear panel (see Figure 2-12).
2. Remove and isolate the spade lug from the terminal marked COM.

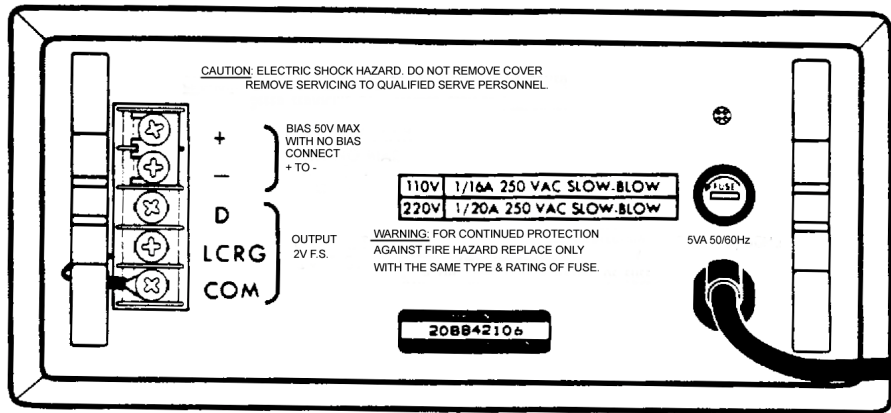

Figure 2-12

To make measurements of grounded unknowns, connect the grounded side of the unknown to the KELVIN KLIPS® with the red insulating hinge-spool and the ungrounded end to the clip with the black spool (see Figure 2-13).

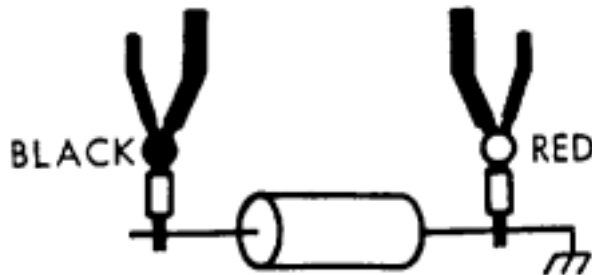

Figure 2-13

A small zero offset may become apparent during low value grounded capacitance measurements. This offset can be corrected by making a reading with the unknown connected only to the red clips and subtracting it from the final measured capacitance.

To return to normal ungrounded measurements reverse the above procedures.

2.3.9 Measuring Battery Impedance

Current producing capabilities of a battery can be determined by using the 253 to measure its impedance. Series resistance and series capacitance measurements can be made on batteries with voltages up to 50V. To measure series resistance:

1. Set the 253 to measure R_s and to the highest measurement range.
2. Remove the shorting bar from the + and – bias terminals. The bias terminals are located on the instrument's rear panel terminal strip.
3. Connect a 500 μF (or larger) capacitor, whose working voltage is greater than the rated voltage of the battery, to the bias terminals (see Figure 2-14). Observe correct polarity when connecting the capacitor.
4. Connect the test leads with the red hinge-spool to the positive battery terminal and the black hinge-spool to the negative (see Figure 2-14).

5. Move the range switch to the range with the highest resolution displayed (see Section 2.2.5) unless that range uses excessive test current for the size of battery being measured. See Table 1-1 for range test currents.

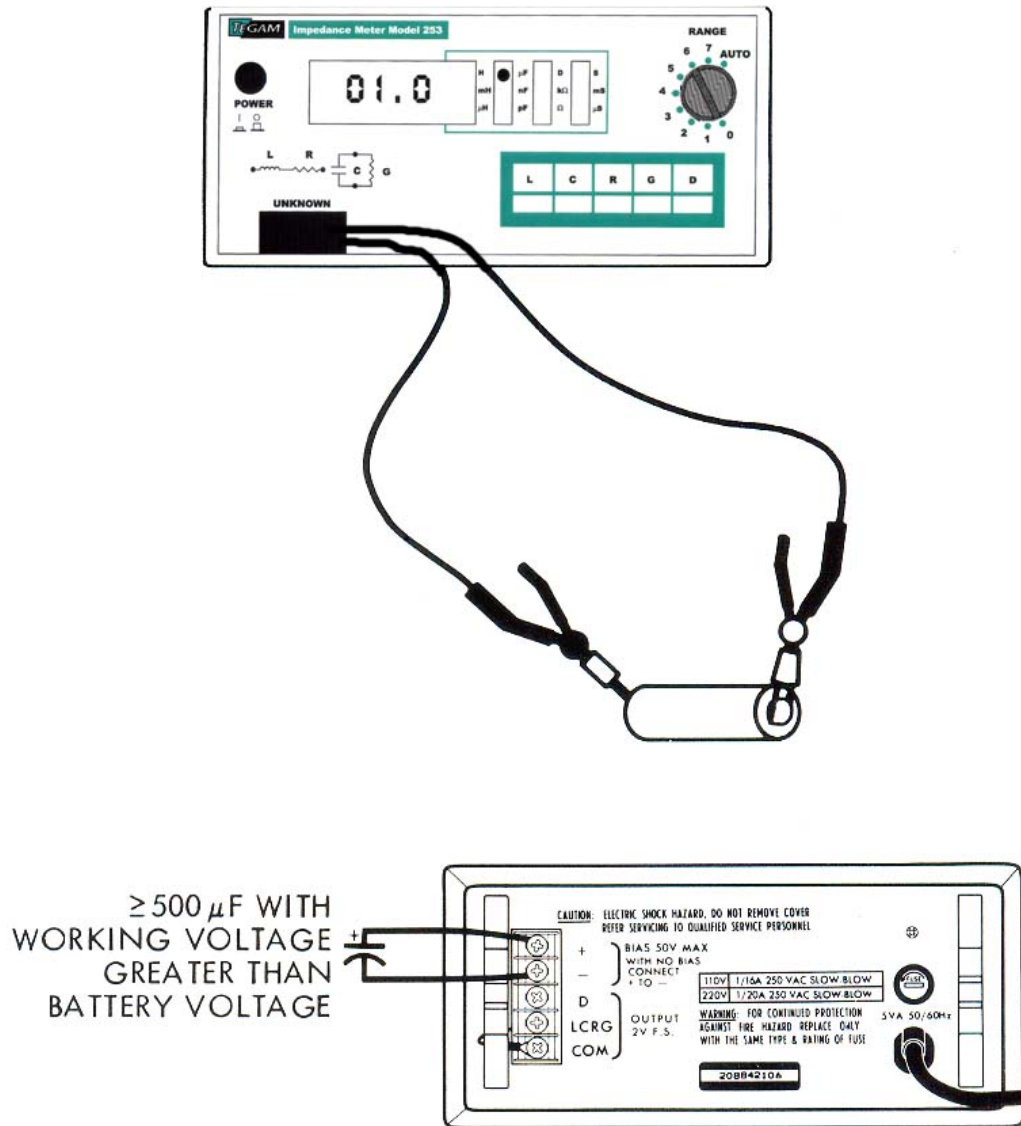

Figure 2-14. Measuring Battery Impedance

The Ls function must be used to measure the series capacitance of a battery. Instrument set up is the same as for Rs measurements (Figure 2-14). A negative reading will be shown, and the following equation must be used to convert the "-Ls" reading to "+ Cs" values:

$$C_s = \frac{1}{(2\pi f)^2 (-L_s)}$$

Where: f = frequency in hertz
 Cs = series capacitance in farads
 Ls = series inductance in henrys

Care must be taken so the measurement current level of the 253's internal source does not exceed the rating of the battery being tested. See Table 1-1 for range test currents.

2.3.10 Component Sorting

Model 253, when used with Tegam, Inc. Model 1412B Limits Comparator, sorts components according to percent deviation and dissipation factor, simultaneously. Component sorting can be manual or automatic; Model 1412B provides four contact closures for operating automatic component handling equipment.

Model 1412B front panel controls set upper and lower limits around a nominal value (L, R, C, or G), with either of two full scale ranges - - 10% or 100%. An upper limit for dissipation factor (D) is also set by a front panel control. Test results are shown by four front panel LEDs. They indicate:

- GO indicates value between - and + % limits and less than D limit.
- LO indicates value less than - % limit.
- HI indicates value greater than + % limit.
- D HI indicates dissipation factor greater than limit.

Connect the 253 and 1412B as shown in Figure 2-15.

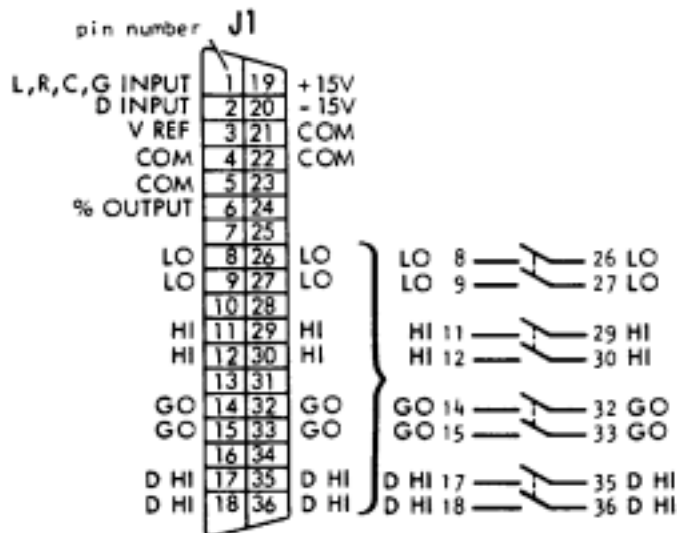
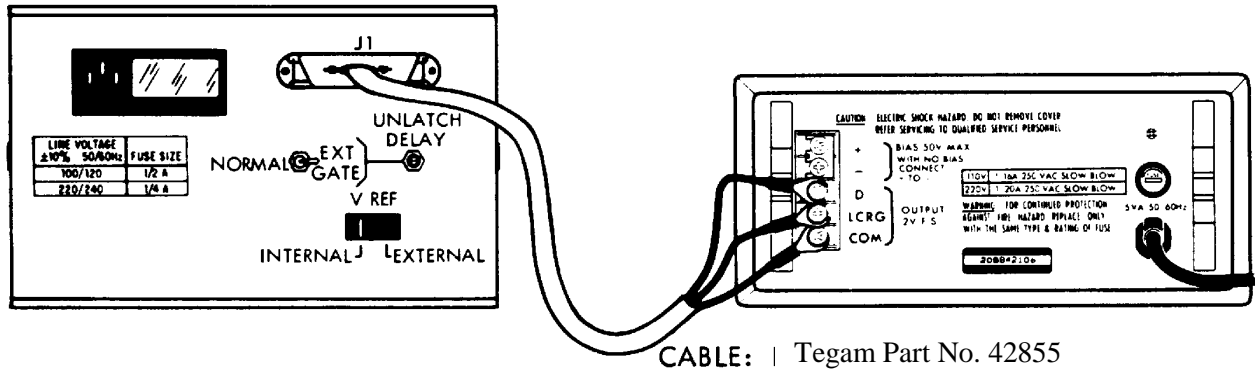

NOTE: For resistive unknowns connect the D lead to the COM terminal

Figure 2-15 Model 253 and Model 1412B Interconnection

Operation

The following instructions assume Model 253 and Model 1412B are connected and both are turned on.

Model 253 setup: (for capacitor sorting)

1. Push the C button on the Model 253 front panel.
2. Set the range switch to give maximum resolution on the display.

Model 1412B setup:

1. Set the rear panel V REF switch to INTERNAL.
2. Set NOMINAL VALUE switches to anticipated value.
3. Set LIMITS FULL SCALE toggle switches, and % LIMITS and D LIMIT dials to desired limits.

The measurement:

Connect unknown to the Model 253. If the unknown is within the set limits, the GO LED will light. If it is not within limits, the appropriate indicator will light.

Example: Sort 15 μ F capacitors within +25%, -15% limits with a maximum dissipation limit of 0.0250.
 Instrument set up is as follows:

Model 253:

Function and Range settings

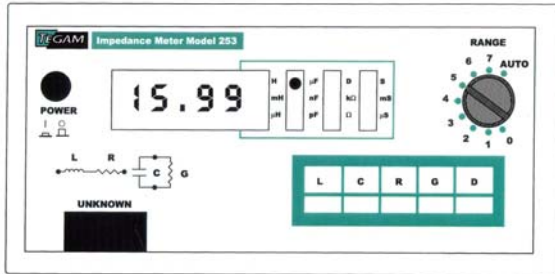

Model 1412B:

Nominal value setting

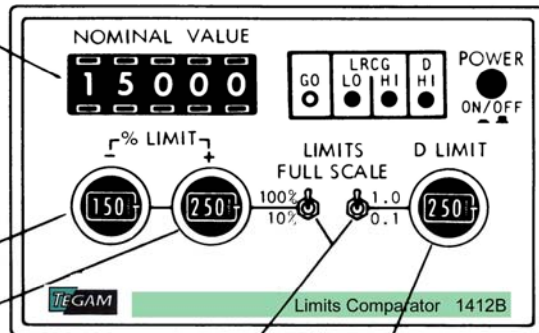

- % Limits setting

+ % Limits setting

LIMITS FULL SCALE Toggle switches settings

D Limit setting

Connect the unknown and observe indicator lights. If the LO LED is lit, the unknown is lower than the lower % limit. Similarly, if the HI LED is lit, the unknown is a larger value than the upper % limit. If the D HI LED is lit, the dissipation factor of the unknown exceeds the set limit. If the Go indicator is lit, the unknown value is within the desired limits; in the example, 15 μ F, + 25%, -15%, with a dissipation factor less than 0.0250.

For further operating instructions, see the Model 1412B instruction manual.

SECTION 3 CIRCUIT DESCRIPTIONS

3.1 GENERAL DESCRIPTION

When measuring C_p or G_p , a voltage is applied across the unknown and range resistor in Figure 3-1. The voltage across the unknown is held constant to within one part in several thousand by the 1kHz oscillator feedback control circuit. A current proportional to the value of the unknown impedance is produced through the range resistor. The resultant voltage drop across the range resistor is separated into two vector components by the Phase Sensitive Detectors (PSD) and Reference Voltage Generator (RVG). Receiving gating signals from RVG, the PSD will measure G_p , the component in phase (0°) with RVG, and C_p , the component at quadrature (90°). The selected detector output is then fed to the A/D Converter which has a readout of 1000 counts/volt.

When measuring L_s or R_s , a voltage is applied across the unknown and range resistor in Figure 3-1. The voltage across the range resistor is held constant to within one part in several thousand by the 1kHz oscillator feedback control circuit. With a constant current flowing through the unknown, a voltage proportional to the value of the unknown impedance is developed across the unknown. The resultant voltage drop is separated into two vector components by the Phase Sensitive Detector (PSD) and Reference Voltage Generator (RVG). Receiving gating signals from the RVG, the PSD will measure R_s , the component in phase (0°) with the RVG, and L_s , the component at quadrature (90°). The selected detector output is then fed to the A/D Converter which has a readout of 1000 counts/volt.

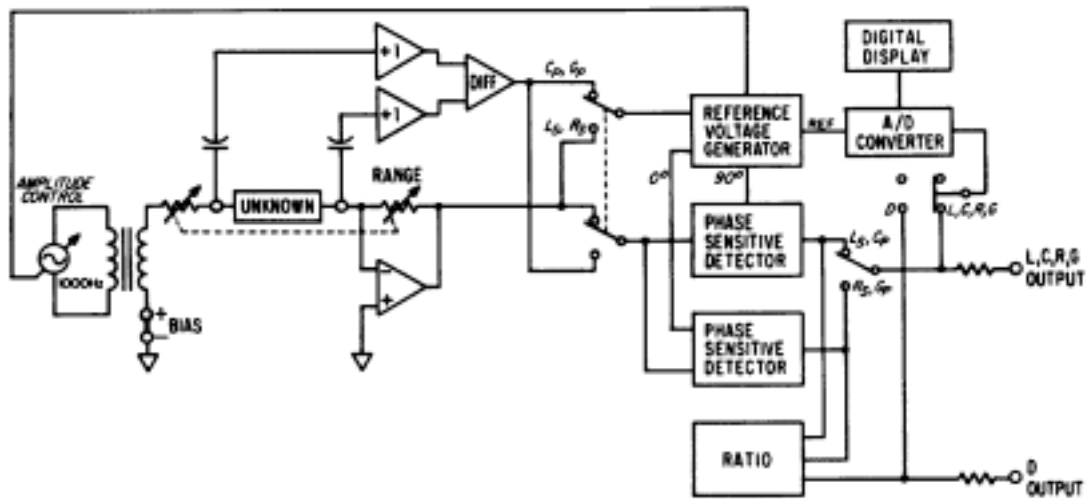

Figure 3-1. Model 253 Simplified Diagram

When measuring the dissipation factor (D) of inductors or capacitors, an analog ratio circuit is used. This circuit compares the loss component (R_s or G_p) to the reactive component (L_s or C_p) and presents a voltage proportional to D to the A/D Converter.

Analog output voltages are available at the rear of Model 253 for the selected function (L, C, R or G) and simultaneous D (for L or C unknowns).

SECTION 4 MAINTANCE



TO AVOID PERSONAL INJURY FROM ELECTRIC SHOCK DO NOT REMOVE INSTRUMENT COVERS OR PERFORM ANY MAINTANCE OTHER THAN DESCRIBED IN THIS MANUAL. INSTALLATION AND MAINTENANCE PROCEDURES DESCRIBED IN THIS MANUAL ARE TO BE PERFORMED BY QUALIFIED SERVICE PERSONNEL ONLY.

4.1 CALIBRATION PROCEDURE

Although Model 253 is inherently stable, good maintenance practices suggest it be calibrated every six months; more often if used in extreme environments or if inaccurate readings are suspected.

<u>Equipment Required</u>	<u>Minimum Specifications</u>
Frequency Counter	Measure 1000Hz with resolution of 1Hz
Digital Voltmeter	Resolution of 100 μ VDC
Resistance Standard	1000 Ω \pm 0.05%, non-inductive such as Tegam Model SR1.
Capacitance Standard	100nF, \pm 0.05%, silvered mica or polystyrene
Dissipation Factor Standards	1 μ F Decade Capacitor, 5 dial, polystyrene, D < 0.0002; 10 μ F polystyrene capacitor with D known to \pm 0.001; 100 μ F capacitor with D known to \pm 0.001
KELVIN KLIPS® Four-Terminal Clips	Tegam Part No. 43072

Refer to Figure 4-1 for adjustment locations.

4.1.1 Power Supply Check

Setup – Turn on instrument and allow ten minute warm-up period; then remove cover. Check – Power supply voltages at C44 and C45 should be + and –5V \pm 5% (4.75V to 5.25V). Use rear panel COM terminal for voltmeter low input.

4.1.2 Oscillator Adjust

Setup – Press R function button. Set RANGE switch to 2000 ohms and short test leads together. Connect voltmeter high input to Test Socket (J5) pin (2) and frequency counter input to J5 pin (1). Use rear panel COM terminal for circuit common. Adjustment – Set trimmer S for DVM reading of 0V (\pm 0.2V). Counter reading should be 1000Hz (\pm 10Hz).

4.1.3 L,C,R,G Alignment

1. R, G PHASE DETECTOR ZERO TRIM. Setup – Press R function button and set RANGE switch to 2000 ohms and short test leads together. Connect DVM input to J5 pin (6). Adjustment – Set trimmer P for 0V \pm 0.3mV.
2. UNKNOWN AMP COMMON MODE TRIM. Setup – Press R function button and set RANGE switch to 2 ohms and short test leads together. Connect DSVM input to J5 pin (5). Adjustment – Adjust trimmer J for DVM reading of 0V \pm 0.3mV at J5 pin (6).
3. L, C PHASE DETECTOR ZERO TRIM. Setup – Press L function button and set RANGE switch to 200mH. Short test leads together and connect DVM input to J5 pin (5). Adjustment – Set trimmer M for 0V \pm 0.3mV.
4. L, C, R, G OUTPUT AMP ZERO TRIM. Setup – Same as step 3 except connect DVM input to J5 pin (4). Adjustment – Set trimmer V for 0V \pm 0.3mV on DVM.
5. UNKNOWN AND RANGE AMP PHASE TRIM. Setup – Press C function button and set RANGE switch to 200nF. Connect decade capacitor to unknown test leads and set at 160nF (\pm 5%). Adjustment – Note voltage at J5 pin (6) and then push L function button, again noting J5 pin (6) voltage. The two should be equal (\pm 0.3mV). If not, adjust trimmer X until they are. Next adjust trimmer D for 0V \pm 0.3mV output at J5 pin (6) for both L and C functions.
6. QUADRATURE GATE PHASE TRIM. Setup – Press R function button and set RANGE switch to 2000 Ω . Connect 1000 Ω (\pm 0.05%) standard to unknown test leads. Adjustment – Set trimmer L for DVM reading of 0V \pm 0.3mV at J5 pin (5).
7. R, G FULL SCALE TRIM. Setup – Same as step 6. Adjustment – Set trimmer K for front panel digital reading of 1000. With DVM, read voltage at J5 pin (4) and adjust trimmer R for + 1.0V (\pm 0.5mV).
8. L, C FULL SCALE TRIM. Setup – Press C function button and set RANGE switch to 200nF. Connect 100nF (\pm 0.05%) standard to the unknown test leads. Adjustment – Set trimmer N for front panel reading of 1000.

4.1.4 Dissipation Factor (D) Alignment

1. LOW LEVEL ZERO TRIM. Setup – Press C function button and set RANGE switch to 200nF. Connect a low loss ($D < 0.0002$) decade capacitor to unknown test leads. Adjustment – Set the decade capacitor to 105nF and, with a DVM, note the voltage at J5 pin (3) or D output terminal at the rear panel. Set the decade to 5nF and again note the voltage. If the two voltages are not equal ($+/-1\text{mV}$), adjust trimmer W until switching between 105nF and 5nF produces equal readings.
2. HIGH LEVEL ZERO TRIM. Setup – Same as step 1. Adjustment – Set decade capacitor to 100nF and adjust trimmer U until voltage at J5 pin (3) or D output is $0\text{V} \pm 0.3\text{mV}$.
3. D FULL SCALE TRIM. Setup – Same as step 1. Adjustment – Set the decade capacitor for a front panel C reading of 159.2nF. Connect the 1000 ohm standard resistor in parallel with the decade capacitor. Set trimmer T for a front panel D reading (push D button) of 1.000.
4. 200pF RANGE D TRIM. Setup – Press C function button and set RANGE switch to 200 pF. Connect the low loss ($D < 0.0002$) decade capacitor to unknown test leads. Adjustment – Set the decade to 100pF ($+/-20\%$) and adjust trimmer H for $0\text{V} +/-0.3\text{mV}$ at J5 pin (3), or D output.
5. 2nF RANGE D TRIM. Setup – Same as step 4, except set RANGE switch to 2nF. Adjustment – Set decade to 1nF ($+/-20\%$) and adjust trimmer F for $0\text{V} +/-0.3\text{mV}$ at J5 pin (3), or D output.
6. 20nF RANGE D TRIM. Setup – Same as step 4, except set RANGE switch to 20nF. Adjustment – Set decade to 10nF ($+/-20\%$) and adjust trimmer E for $0\text{V} +/-0.3\text{mV}$ at J5 pin (3), or D output.
7. 2 μF RANGE D TRIM. Setup – Same as step 4, except set RANGE switch to 2 μF . Adjustment – Set decade to 1 μF ($+/-20\%$) and adjust trimmer C for $0\text{V} +/-0.3\text{mV}$ at J5 pin (3), or D output.
8. 20 μF RANGE D TRIM. Setup – Set RANGE switch to 20 μF and connect a 10 μF ($+/-20\%$) capacitor (D known to $+/-0.001$) to unknown test leads.

Adjustment – Adjust trimmer B for front panel D reading (push D button) equal to D value of the 10 μF capacitor.

9. 200 μH RANGE D TRIM. Setup – Press the L function switch and set the RANGE switch to 200 μH . Short the Kelvin Klips together and note the zero inductance (approximately + 5 counts) for use in the adjustment. Connect a 1.2 ohm, 5% carbon composition resistor to the test leads.

Adjustment – Adjust trimmer A for a display equal to, or -1 count from the zero inductance value noted when the Kelvin Klips were shorted together.

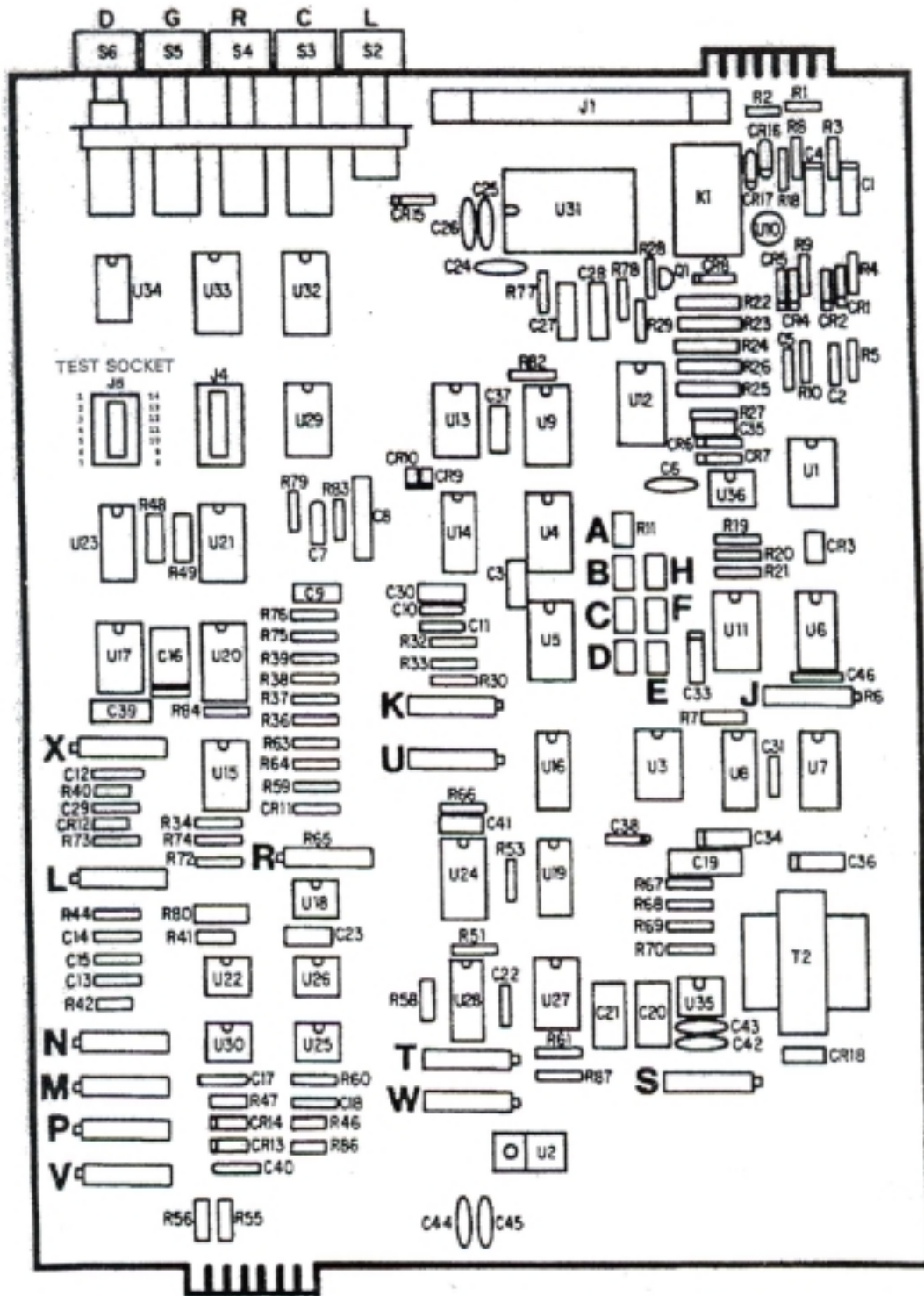

Figure 4-1

4.2 MAINTENANCE

This section of the manual contains maintenance information for use in preventative maintenance, and troubleshooting of the Model 253.

4.2.1 Preventative Maintenance



REMOVAL OF INSTRUMENT COVERS MAY CONSTITUTE AN ELECTRICAL HAZARD AND SHOULD BE ACCOMPLISHED BY QUALIFIED SERVICE PERSONNEL ONLY.

Preventive maintenance performed on a regular basis will improve the reliability of this instrument. It may include cleaning, visual inspection, or even monitoring the operating environment.

4.2.1.1 Cleaning



AVOID THE USE OF CHEMICAL CLEANING AGENTS WHICH MIGHT DAMAGE THE PLASTICS USED IN THIS UNIT. DO NOT APPLY ANY SOLVENT CONTAINING KETONES, ESTERS OR HALOGENATED HYDROCARBONS. TO CLEAN, USE ONLY WATER SOLUBLE DETERGENTS, ETHYL, METHYL, OR ISOPROPYL ALCOHOL.

Exterior. Loose dust may be removed with a soft cloth or a dry brush. Water and mild detergent may be used; however, abrasive cleaners should not be used.

Interior. Use low-velocity compressed air to blow off the accumulated dust. Hardened dirt can be removed with a cotton-tipped swab, soft, dry cloth, or a cloth dampened with a mild detergent and water.

4.3 Preparation for Calibration or Repair Service:

No user serviceable parts are available for this equipment. If a problem arises and you have verified that the cause for malfunction cannot be solved in the field then the instrument should be sent to TEGAM for service. Before sending a unit in for service, an RMA, (Returned Material Authorization), number must be assigned to your instrument. You can contact TEGAM customer service via the TEGAM website, www.tegam.com or calling 440.466.6100 or 800.666.1010.

The RMA number is unique to your instrument and will help us identify you instrument and to address the particular service request by you, which is assigned to that RMA number.

Of even importance, a detailed written description of the problem should be attached to the instrument. Many times repair turnaround is unnecessarily delayed due to a lack of repair instructions or of a detailed description of the problem.

This description should include information such as measurement range, and other instrument settings, type of components being tested, are the symptoms intermittent?, conditions that may cause the symptoms, has anything changed since the last time the instrument was used?, etc. Any detailed information provided to our technicians will assist them in identifying and correcting the problem in the quickest possible manner. Use a copy of the Repair and Calibration Service form provided on the next page.

Once this information is prepared and sent with the instrument to our service department, we will do our part in making sure that you receive the best possible customer service and turnaround time possible.

4.4 Warranty:

TEGAM, Inc. warrants this product to be free from defects in material and workmanship for a period of one year from the date of shipment. During this warranty period, if a product proves to be defective, TEGAM Inc., at its option, will either repair the defective product without charge for parts and labor, or exchange any product that proves to be defective.

TEGAM, Inc. warrants the calibration of this product for a period of 6 months from date of shipment. During this period, TEGAM, Inc. will recalibrate any product, which does not conform to the published accuracy specifications.

In order to exercise this warranty, TEGAM, Inc., must be notified of the defective product before the expiration of the warranty period. The customer shall be responsible for packaging and shipping the product to the designated TEGAM service center with shipping charges prepaid. TEGAM Inc. shall pay for the return of the product to the customer if the shipment is to a location within the country in which the TEGAM service center is located. The customer shall be responsible for paying all shipping, duties, taxes, and additional costs if the product is transported to any other locations. Repaired products are warranted for the remaining balance of the original warranty, or 90 days, whichever period is longer.

Warranty Limitations:

The TEGAM, Inc. warranty does not apply to defects resulting from unauthorized modification or misuse of the product or any part. This warranty does not apply to fuses, batteries, or damage to the instrument caused by battery leakage.

Statement of Calibration:

This instrument has been inspected and tested in accordance with specifications published by TEGAM Inc. The accuracy and calibration of this instrument are traceable to the National Institute of Standards and Technology through equipment, which is calibrated at planned intervals by comparison to certified standards maintained in the laboratories of TEGAM Inc.

Contact Information:

TEGAM INC.
10 TEGAM WAY
GENEVA, OHIO 44041
PH: 440.466.6100
FX: 440.466.6110
EMAIL: sales@tegam.com



TEN TEGAM WAY, GENEVA, OHIO 44041
PHONE 440-466-6100 FAX 440-466-6110

WARRANTY OF TRACEABILITY

The reference standards of measurement of Tegam, Inc., are compared with the U.S. National Standards through frequent tests by the U.S. National Institute of Standards and Technology. The Tegam working standards and testing apparatus used are calibrated against the reference standards in a rigorously maintained program of measurement control.

The manufacture and final calibration of all Tegam instruments are controlled by use of the Tegam reference and working standards and testing apparatus in accordance with established procedures and documented results. (Reference ANSI/NCSL Z540-1-1994)

Final calibration of this instrument was performed with reference to the mean values of the Tegam reference standards or to ratio devices that were verified at the time and place of use.

DISCLAIMER of IMPLIED WARRANTIES

The foregoing warranty of Tegam is in lieu of all other warranties, expressed or implied. Tegam specifically disclaims any implied warranties of merchantability or fitness for a particular purpose. In no event will Tegam be liable for special or consequential damages. Purchaser's sole and exclusive remedy in the event any item fails to comply with the foregoing express warranty of Tegam shall be to return the item to Tegam, shipping charges prepaid, and at the option of Tegam obtain a replacement item or a refund of the purchase price.

